

Find it at



**PRECISION
FLUID POWER, INC.**
Hydraulic Sales & Repair
800-728-5168 PrecisionFluidPower.com



New Generation Hydraulics

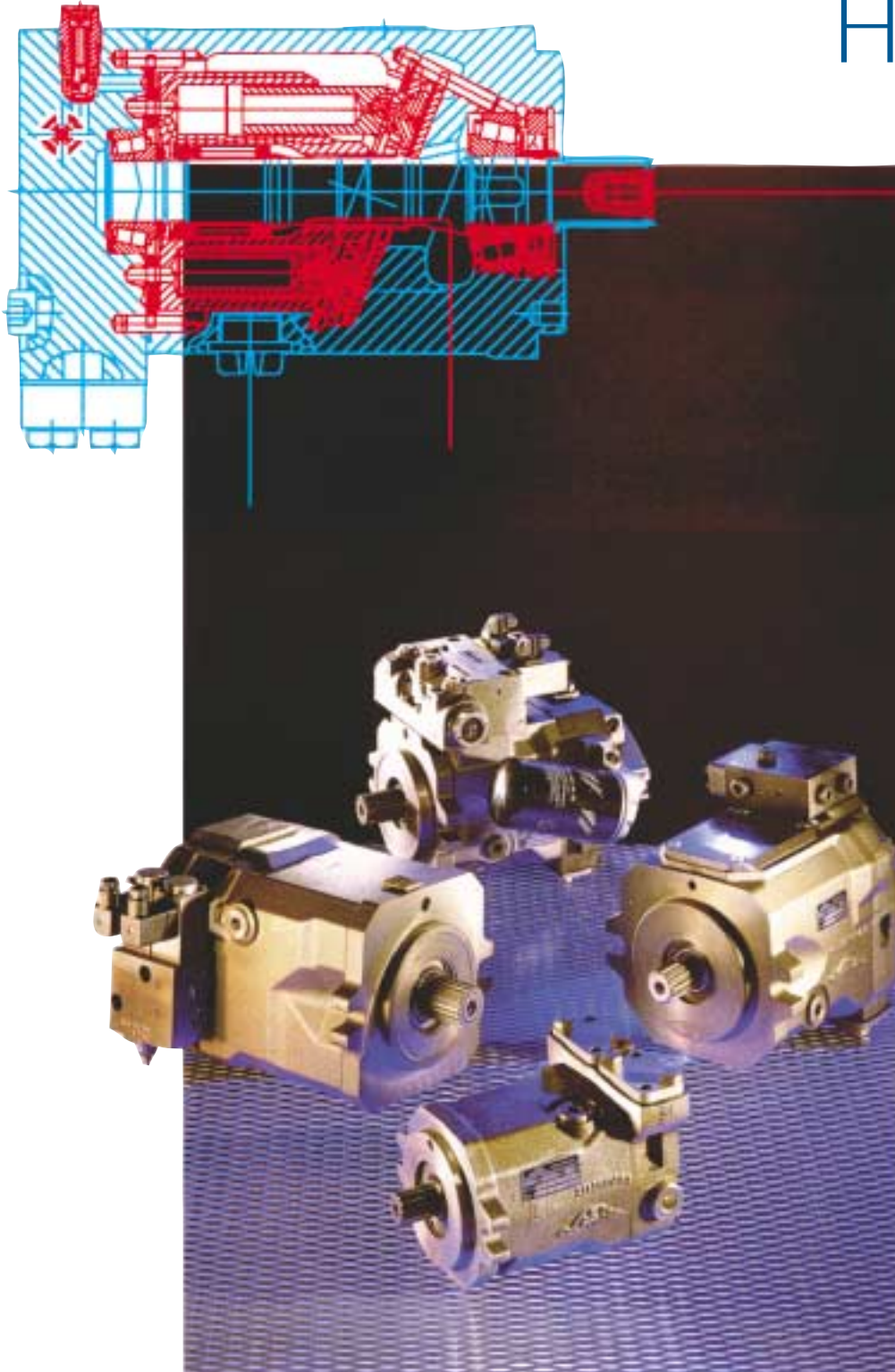

Series 02

New Generation Series 02

Objectives

Linde engineers set the target to design a new range of axial piston pumps and motors to carry Linde Hydraulics well into the next millennium.

The main objectives were:-

1. Common Rotating Groups for both Pumps and Motors.
2. Extreme Compactness with High Power Density.
3. Suitable for Closed and Open Loop Circuits.
4. Common Installation Configurations.
5. High Performance and Efficiency.
6. Integrated System Protection.
7. Reliability and Durability.
8. Modular Construction.
9. Low Noise Level.
10. Cost Effective.

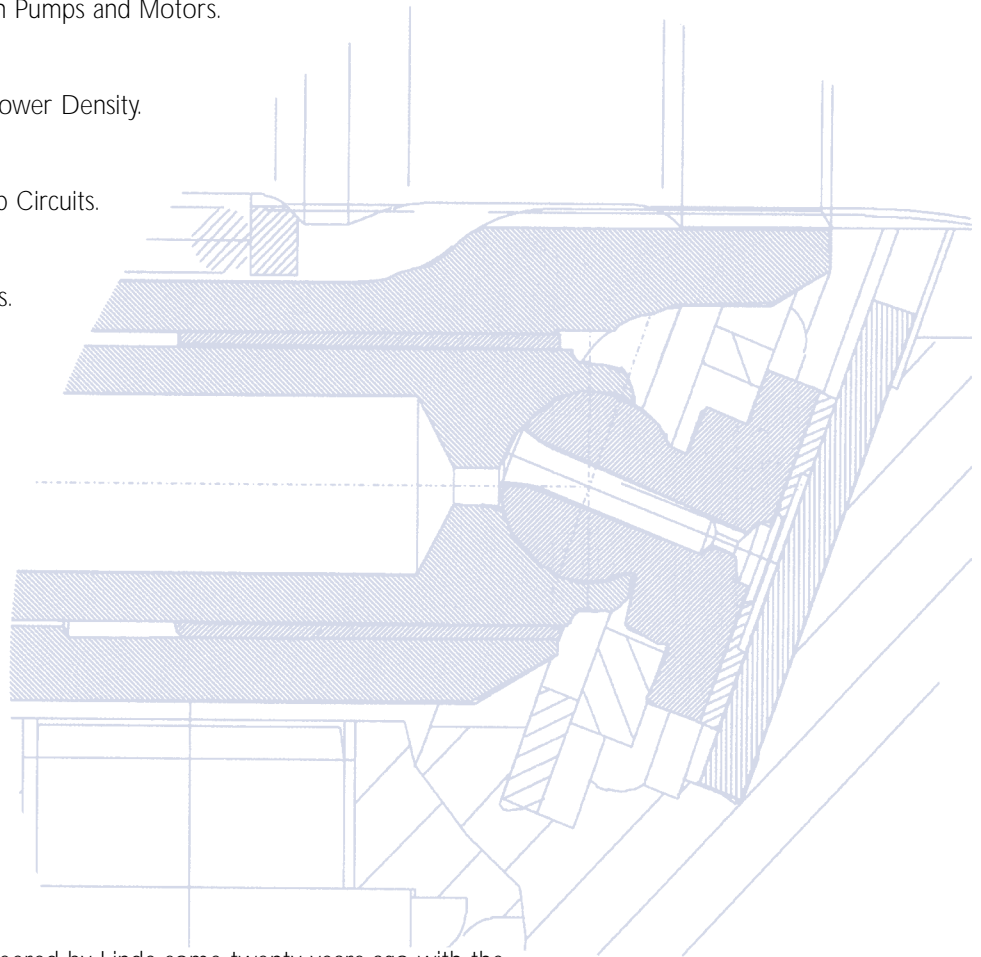

Many of the features listed above were pioneered by Linde some twenty years ago with the well proven 'B' series swash plate pumps and bent axis motors. Hundreds of thousands of which have been applied worldwide by leading international manufacturers of both mobile and industrial machines and exemplified in Linde's own range of high volume production for lift trucks. The direct feed back from this in-house design and development of both hydrostatic transmission and vehicles give Linde engineers a unique advantage over other suppliers of axial piston hydraulic equipment.

The question, therefore, was how to improve on what is already a very successful range of axial piston hydraulic pumps and motors.

New Generation Series 02

Realization

Linde engineers solved the task set for them with an innovative redesign of the basic in-line axial piston, swash plate rotating group.

Traditional swash plate units have the ball on the piston end which locates into a socket on the slipper pad. By putting the ball end on the slipper pad the ball itself now goes inside the piston thus reducing the overall unit length, this arrangement also permits the swash angle to be increased from the conventional 18 degrees to **21 DEGREES**. The swept volume for the same overall size is therefore increased and as displacement per revolution multiplied by pressure and speed equals fluid power, then the objective of higher power density was achieved.

Cost effectiveness was obtained by the use of common rotating groups in both pumps and motors and many parts also are common to units of different sizes.

A significant reduction in total number of necessary parts was achieved thus minimizing inventory of components both for production and spares to the benefit of Linde customers.

Further reduction was made by considerable investment in dedicated machine tools and automatic manufacturing systems to cut machining cycle times. At the same time, improved machining technique and the use of modern materials, resulted in better surface finishes of the dynamic components allowing reduced clearances for higher volumetric efficiencies and lower friction losses for improved mechanical efficiency.

Features common to the entire **SERIES 02** are:

- Pumps and Motors fitted with Linde **UNIQUE 21° SWASH ANGLE** reverse piston ball/slipper arrangement.
- SAE 2 bolt Mounting Flanges with SAE and ANSI Splined Shafts and SAE High Pressure Ports. (420 bar)

These rotating groups have been operational since 1994 and are therefore fully proven before being released for general application.

The design Objectives were Realized!

21 degrees for the 21st century

HMV & HMR ...- 02 Variable Motors

for closed and open loop applications

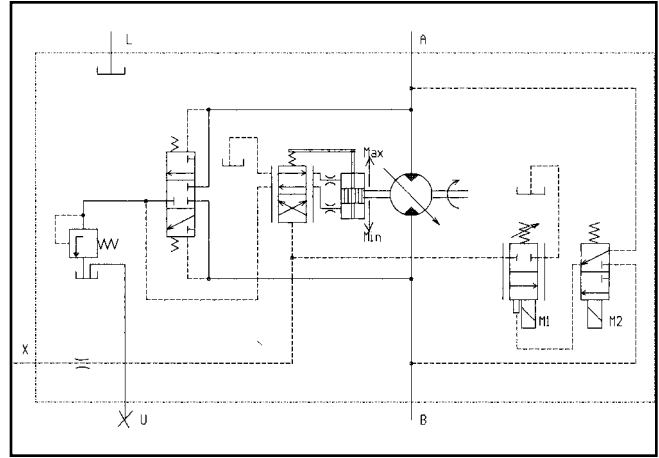

<i>Sizes</i>	55, 75, 105, 135 cm ³ /rev
<i>Pressure</i>	rated 420 bar, max. 500 bar
<i>Speed</i>	up to 4500 rev/min
<i>Controls (for HMV)</i>	Hydraulic Remote, electro-Hydraulic, Automotive Two position, infinitely variable or infinitely variable with pressure over-ride
<i>Regulators (for HMR)</i>	System pressure related, max. displacement over-ride, Braking pressure over-ride
<i>Mounting</i>	SAE 2 bolt flanges, SAE and ANSI splined shafts
<i>Features</i>	Plug-in types available. Counter-balance valves for open loop available Speed sensor optional
<i>Advantages</i>	Extremely compact with high power density High starting torque efficiency Wide torque/speed ratio Low noise level



Linde Group

The Linde Group, founded by Professor Dr Carl von Linde in 1879 is devoted to the research, design, development and manufacture of high technology based products in the fields of:

Engineering & Contracting

Industrial Trucks and Hydraulics

Industrial Gases

Refrigeration

Today, the group employs over 40,000 people and has a world wide sales exceeding 8 billion Euro per annum.

Linde Hydraulics

For over four decades Linde has manufactured high pressure axial piston hydraulics, beginning in the 1950's with the worlds first volume production of transport and forklift trucks fitted with hydrostatic transmission.

Since then many millions of rotating groups have been produced, used in a wide range of closed and open loop systems for both mobile and industrial applications.

Linde has concentrated on this technology with considerable success culminating now in the new SERIES-02 rotating groups designed for heavy duty use into the 21st century.

21 degrees for the 21st century



LINDE AG, Werksgruppe Flurförderzeuge und Hydraulik, Werk 2, Aschaffenburg-Nilkheim

Linde AG
Werksgruppe Flurförderzeuge
und Hydraulik
Postfach 62, D-63736 Aschaffenburg
Telefon: (06021) 99-0
Telefax: (06021) 99-1579

P/N 888 006 6478

Linde Hydraulics Corp.
P.O. Box 82
5089 Western Reserve Road
Canfield
OH 44406
Phone (330) 533-6801
Fax: (330) 533-2091
www.lindeamerica.com

